

AI808P Series Intelligent Temperature Controller User Manual



Features:

- ⊙ TC / RTD / Analog signal universal input;
- ⊙ With display, alarm, adjusting and communication function;
- ⊙ Advanced Fuzzy algorithm & Two Degrees of Freedom PID Arithmetic;
- ⊙ Optional control output, modularization design;
- ⊙ Good anti-interference;
- ⊙ Up to 50 programmable segments control;
- ⊙ Color bar display

For your safty, please read following content carefully before you are using our temperature controller!

■ Safe Caution

※ Please read the manual carefully before you use the temperature controller.

※ Please comply with the below important points.

⚠ Warning An accident may happen if the operation does not comply with the instruction.

⚠ Notice An operation that does not comply with the instruction may lead to product damage.

※ The instruction of the symbol in the manual is as below.

⚠ An accident danger may happen in a special condition.

⚠ Warning

1. A safty protection equipment must be installed or please contact with us for the relative information if the product is used under the circumstance such as nuclear control, medical treatment equipment, automobile, train, airplane, aviation and equipment etc.. Otherwise, it may cause serious loss, fire or person injury.
2. A panel must be installed, otherwise it may cause creepage (leakage).
3. Do not touch wire connectors when the power is on, otherwise you may get an electric shock.
4. Do not dismantle or modify the product. If you have to do so, please contact with us first. Otherwise it may cause electric shock and fire.
5. Please check the connection number while you connect the power supply wire or input signal, otherwise it may cause fire.

⚠ Caution

1. This product cannot be used outdoors. Otherwise the working life of the product will become shorter, or an electric shock accident may happen.
2. When you connect wire to the power input connectors or signal input connectors, the moment of the No.20 AWG (0.50 mm2) screw tweaked to the connector is 0.74n.m - 0.9n.m. Otherwise the connectors may be damaged or get fire.
3. Please comply with the rated specification. Otherwise it may cause electric shock or fire, and damage the product.
4. Do not use water or oil base cleaner to clean the product. Otherwise it may cause electric shock or fire and damage the product.
5. This product should be avoid working under the circumstance that is flammable, explosive, moist, under sunshine, heat radiation and vibration. Otherwise it may cause explosion.
6. In this unit it must not have dust or deposit, otherwise it may cause fire or mechanical malfunction.
7. Do not use gasoline, chemical solvent to clean the cover of the product because such solvent can damage it. Please use some soft cloth with water or alcohol to clean the plastic cover.

1. Model

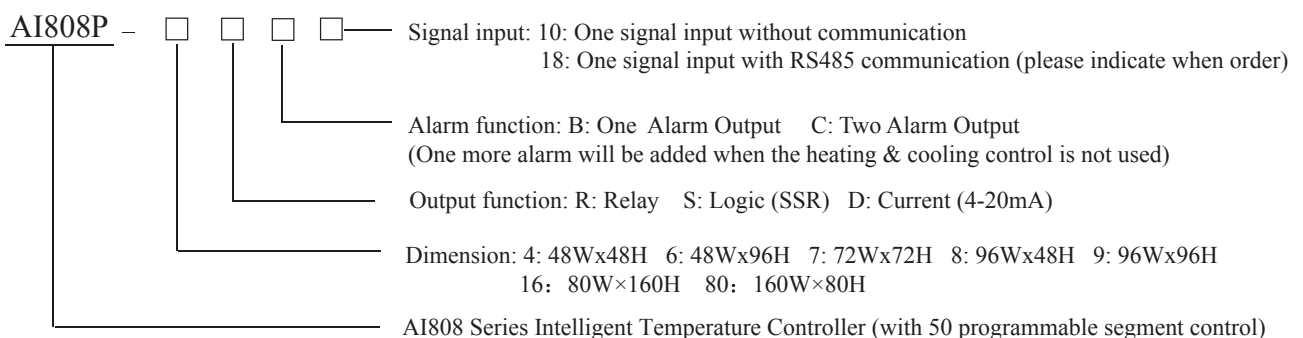

2. Model Illustration

Model	OUT1 (Note 1)	OUT2 (Note 2)	Alarm (Note 3)	Communication
AI808P-4-RB10	Relay output	Relay output	1	No
AI808P-4-SB10	SSR output	Relay output	1	No
AI808P-4-DB10	4-20mA current output	Relay output	1	No
AI808P-4-RB18	Relay output	Relay output	1	RS485 (Modbus RTU)
AI808P-4-SB18	SSR output	Relay output	1	RS485 (Modbus RTU)
AI808P-4-DB18	4-20mA current output	Relay output	1	RS485 (Modbus RTU)

Model	OUT1 (Note 1)	OUT2 (Note 2)	Alarm (Note 3)	Communication
AI808P-□RC10	Relay output	Relay output	2	No
AI808P-□SC10	SSR output	Relay output	2	No
AI808P-□DC10	4-20mA current output	Relay output	2	No
AI808P-□RC18	Relay output	Relay output	2	RS485 (Modbus RTU)
AI808P-□SC18	SSR output	Relay output	2	RS485 (Modbus RTU)
AI808P-□DC18	4-20mA current output	Relay output	2	RS485 (Modbus RTU)

Note:

OUT1: 4-20mA current output, load capacity: 600Ω max.

Relay output capacity: 3A/250V AC

SSR output capacity: 30mA/24V DC

OUT2: Can be workable just under heating-cooling control(OT=3); under other control mode, worked as alarm 3 (For size:48*48 worked as alarm 2)

Relay output capacity: 1A/250V AC.

OUT3: Alarm 3:

Relay output capacity: 1A/250V AC

3. Main Technical Parameters

1) Whole controller parameters

Power supply	AC/DC 100-240V
Total current	<30mA (220VAC)
Ambient temperature	0-50℃
Ambient humidity	45-85%RH
Measurement accuracy	±0.3%FS±3digits 25℃
Control mode	ON/OFF control, PID heating control, PID cooling control, PID heating & cooling control
Communication function	RS485 communication interface, MODBUS protocol
Panel protection level	IP65
Temperature excursion	≤0.01%FS/℃
Dielectric strength	Between the connectors of power supply to relay output, power supply to signal input, relay output to signal input ≥2000VDC; Between the low voltage signal isolated with each other ≥ 600VDC.

2) Input parameter table

No	Signal	Input type	Measuring range	Resolution	Input impedance
0	K	K type thermocouple	-50~1300℃	1℃	>100KΩ
1	J	J type thermocouple	-50~1200℃	1℃	>100KΩ
2	E	E type thermocouple	-50~1000℃	1℃	>100KΩ
3	T	T type thermocouple	-50~400℃	1℃	>100KΩ
4	B	B type thermocouple	600~1800℃	1℃	>100KΩ
5	R	R type thermocouple	-10~1700℃	1℃	>100KΩ
6	S	S type thermocouple	-10~1600℃	1℃	>100KΩ
7	N	N type thermocouple	-50~1200℃	1℃	>100KΩ
8	000	Reserved			
9	Pt	PT100	-199.9~850.0℃	0.1℃	(0.2mA)
10	JPt	JPT100	-199.9~500.0℃	0.1℃	(0.2mA)
11	CU50	CU50	-50.0~150.0℃	0.1℃	(0.2mA)
12	CU100	CU100	-50.0~150.0℃	0.1℃	(0.2mA)
13	V	Linear voltage	0~50mV	0.01%FS	>100KΩ
14	A	Linear current	4~20mA	0.01%FS	<110Ω
15	V	Linear voltage	0~10V	0.01%FS	>100KΩ
16	Rt	Linear resistance	0~400Ω	0.01%FS	(0.2mA)

4. Panel indication

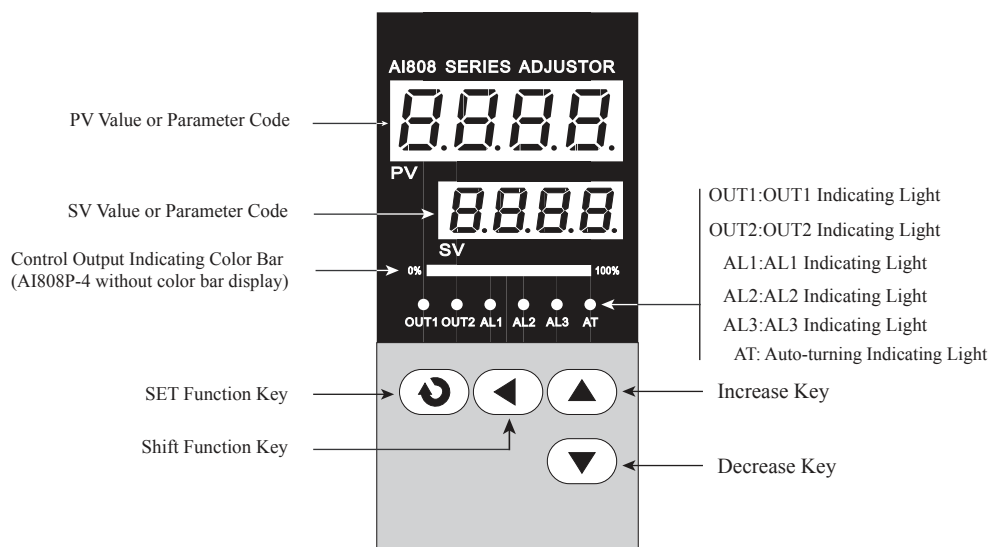

5. Panel Key Operation

- (1) **SET** key: In normal display status, press **SET** key to show setting menu, press **SET** key for a few seconds to show advanced setting menu.
- (2) **Left Arrow** key: press **Left Arrow** key to make the parameters to flicker, the parameters can be changed.
- (3) **Up Arrow**, **Down Arrow** key: to change parameters in setting status, after each operation, press **SET** key to confirm the modify.
- (4) In advanced setting menu, press **SET** key for a few seconds to quit the menu and back to normal display status.
- (5) In normal display status, press **Left Arrow** key for 3 second to start Auto-tuning function, at this moment AT indicating lamp turns on.
- (6) In normal display status, press **Up Arrow** Key to enter into programmable setting menu, press **Down Arrow** Key to enter into programmable parameter setting menu.

6. Operation Sequence

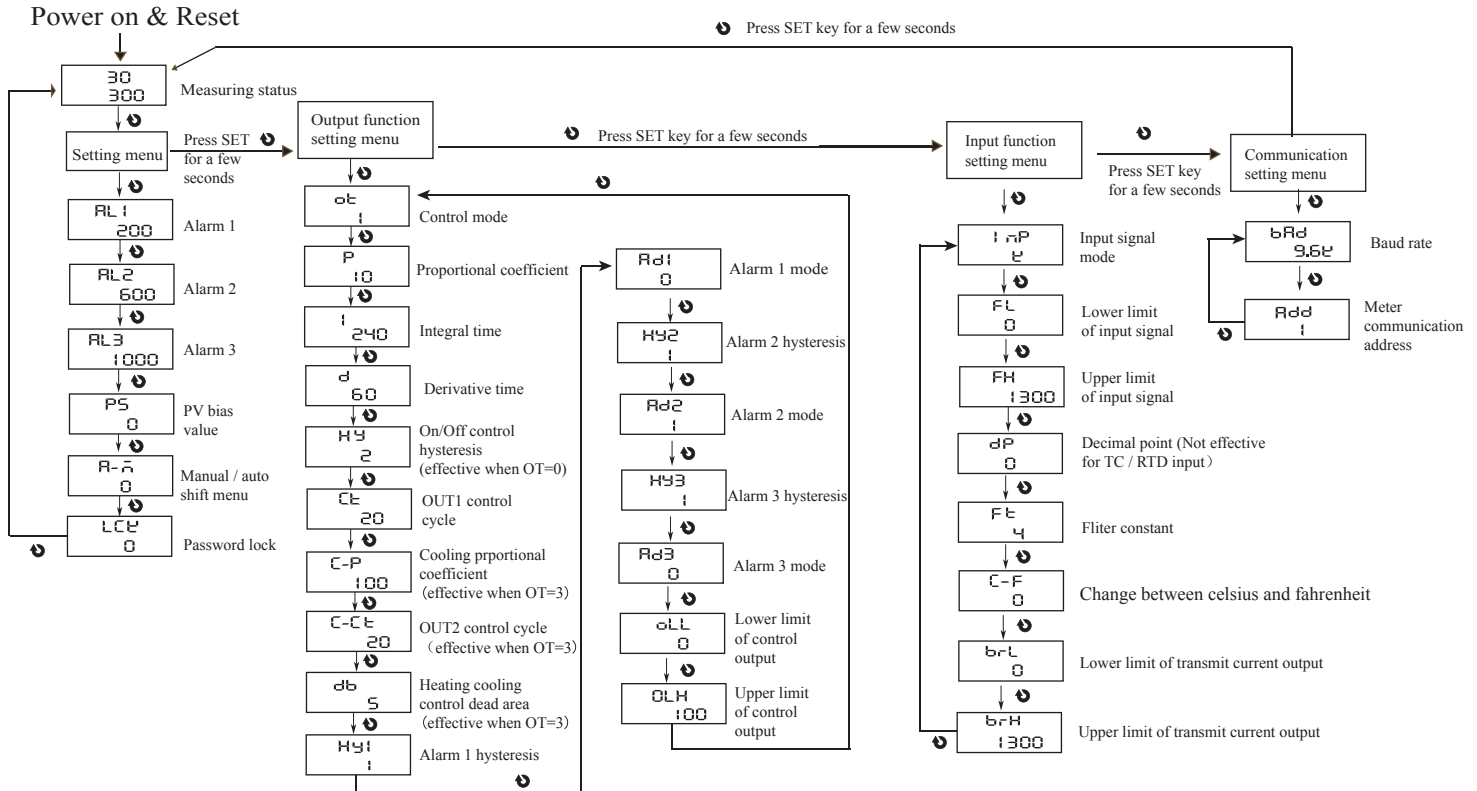

7. Program segment control setting

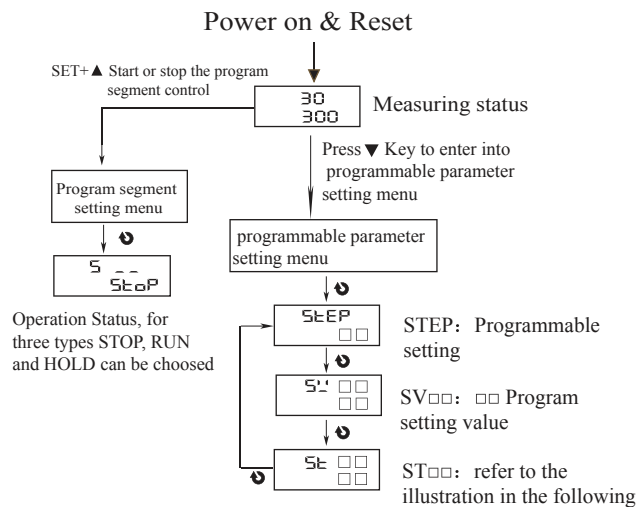

Program segment control setting method:

- There are total 50 programmable segments. For each segment, there are 2 settable parameters: SV □□, ST □□.
- SV □□ value is the object control value of a segment, for example, if SV 01 is 200, the object control value of this segment is 200°C.
- ST □□ value is the control mode parameter of a segment.
 - When ST □□ setting value is -51, it means it has finished this time's programmable segment control, reset to single setting value control mode (refer to example onw)
 - When ST □□ setting value is -50~-1, it means the current segment will jump to the appointed segment, for example, if ST □□=-45, it means the current segment will jump to segment no.45 directly, after the control of this segment is finished.
 - When ST □□ setting value is 0, it means the program segment will jump to the next segment automatically when the temperature get to SV□□.
 - When ST □□ setting value is 1~1440, unit is Minute, it means when runing within this segment, it will reach the setting value with average speed; The meter will stop this segment's operation when this segment's ST□□ value countdown to 0, if the ST□□ value has already come to 0, but PV measuring value does not meet with SV setting value, the program will not leave this segment until SV=P.V. For example: SV□□=200, ST□□=10, the temperature is 30°C, the program will still runing in this segment for 10 minutes and the temperature will rise 17°C per minute.

- 4) In normal display status, press ▼ key for a few seconds to show the parameter setting menu of program segment control.
- 5) In normal display status, press ▲ key for a few seconds to enter into status setting value of program segment control. You can choose RUN, STOP and HOLD three status in this segment.



Example: Here is a control process with below requirement, the relevant setting is on the right side:

- | | |
|--|-------------------|
| 1) Temperature raise to 300℃, | SV01=300、ST01=0; |
| 2) Temperature raise from 300 to 500 (raise 10 degrees/ min) | SV02=500、ST02=20; |
| 3) Temperature falls to 150℃, | SV03=150、ST03=0; |
| 4) Temperature is keep at 150℃ for 60 minute, and then | SV04=150、ST04=60; |
| Program jumps to No.10 segment | ST05= -10; |
| 6) Temperature falls to 25℃ at No.10 segment | SV10=25、ST10=0; |
| 7) Program control stops running at No.11 segment. | |
| exit the segment and control the temperature according to the SV (SV10=25) setting value | ST11=-51; |

8. Menu Parameter

Parameter name	Indication	Setting range	Ex-factory setting
Setting menu			
AL1	Alarm 1 setting value	FL~FH	200
AL2	Alarm 2 setting value	FL~FH	600
AL3	Alarm 3 setting value	FL~FH	1000
PS	Measured value amendment	-100~100	0
MAN	Manual / auto setting: 0: Manual; 1: half-auto (Start Auto-tuning manually) 2: auto (Start Auto-tuning automatically after power on)	0~2	1
LOCK	0001, prohibit to modify SV; 0010, prohibit to modify Menu parameter; 0011, prohibit to modify SV and Menu;	0~9999	0
Output function setting menu			
OUT	Control mode. 0: ON/OFF control; 1: Heating control; 2: Cooling control; 3: Heating & cooling control	0~3	1
P	Proportional coefficient (P=0: ON / OFF control)	0~9999	10
I	Integral time	0~3600	240
D	Derivative time	0~3600	60
HY	ON/OFF control hysteresis	0~1000	2
CT	OUT1 control cycle: Current output is 0; SSR output is 1; the setting range of SSR output can ≥ 4	0~250	20
C_P	Cooling proportional coefficient	1~200	100
C_CT	OUT2 control cycle (setting range can ≥ 4)	1~250	20
DB	Dead area for heating & cooling control	-100~100	5
HY1	Alarm hysteresis 1	0~1000	1
Ad1	Alarm mode 1	0~3	0
HY2	Alarm hysteresis 2	0~1000	1
Ad2	Alarm mode 2	0~3	1
HY3	Alarm hysteresis 3	0~1000	1
Ad3	Alarm mode 3	0~3	0
OLL	Lower limit of control output	0~99	0
OLH	Upper limit of control output	1~100	100
Input function setting menu			
INP	Input signal type	Please refer to input signal table	K
FL	Lower display limit of input signal	Please refer to input signal table	-50
FH	Upper display limit of input signal	Please refer to input signal table	1300
DP	Decimal point setting. Only effective for analog signal input	0~3	0
FT	Filter constant	1~250	60
C-F	0: unit of celsius, 1: unit of fahrenheit	0/1	0
brL	Lower limit display for transmit current output (with current transmit output can workable)	FL~FH	-50
brH	Higher limit display for transmit current output (with current transmit output can workable)	FL~FH	1300
Communication setting menu			
BRd	Baud rate	4. 8K, 9. 6K	9. 6K
Add	Meter communication address	0~250	1

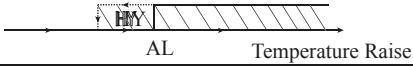
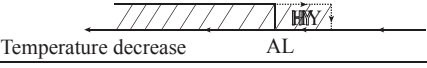
Alarm function table

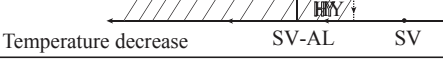
Alarm code	Alarm mode	Alarm output (AL1, AL2 is independent with each other)	Formula
0	Absolute upper limit alarm		Alarm: $PV > AL$ Cancel: $PV \leq AL - HY$
1	Absolute Lower limit alarm		Alarm: $PV < AL$ Cancel: $PV \geq AL + HY$
2	Upper Limit deviation alarm		Alarm: $PV > SV + AL$ Cancel: $PV \leq SV + AL - HY$
3	Lower Limit deviation alarm		Alarm: $PV < SV - AL$ Cancel: $PV \geq SV - AL + HY$

9. Appearance & Mounting Dimension

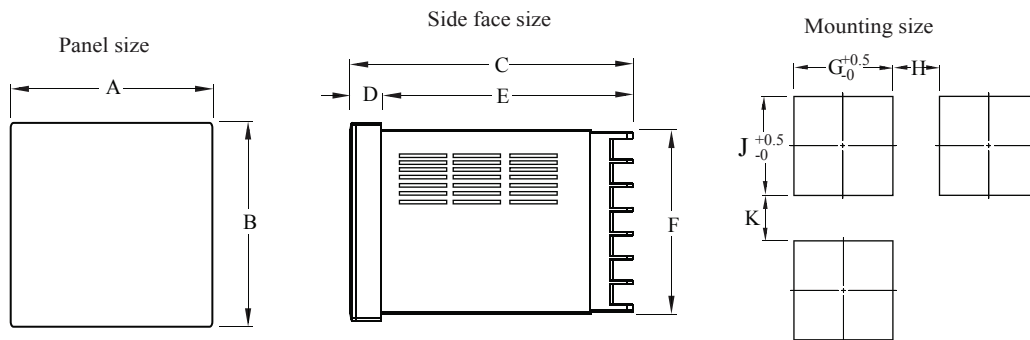

Model	A	B	C	D	E	F	G	H(Min)	J	K(Min)
AI808P-4	48	48	97.5	6.5	91	45	45.5	25	45.5	25
AI808P-6	48	96	97.5	9	88.5	89.5	45	25	90	25
AI808P-7	72	72	97.5	9	88.5	67	67.5	25	67.5	25
AI808P-8	96	48	97.5	9	88.5	44.5	90	25	45	25
AI808P-9	96	96	97.5	9	88.5	91.5	92	25	92	25
AI808P-80	160	80	96	13	83	75.5	155.5	30	76	30
AI808P-16	80	160	96	13	83	155	76	30	155.5	30

Unit: mm

10. Connection Drawing

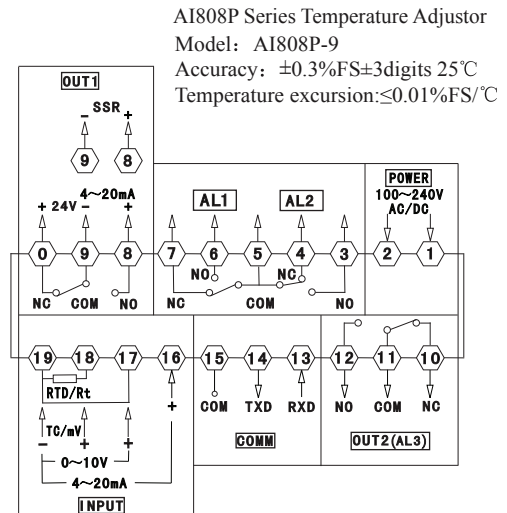
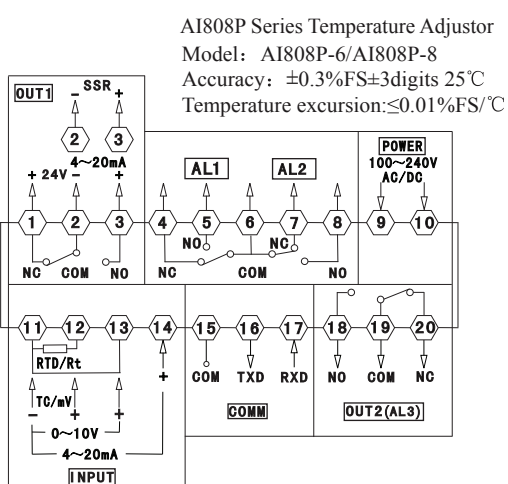

AI808P Series Temperature Adjustor
 Model: AI808P-16/AI808P-80
 Accuracy: 0.3%FS±3digits 25℃
 Temperature excursion:≤0.01%FS/℃

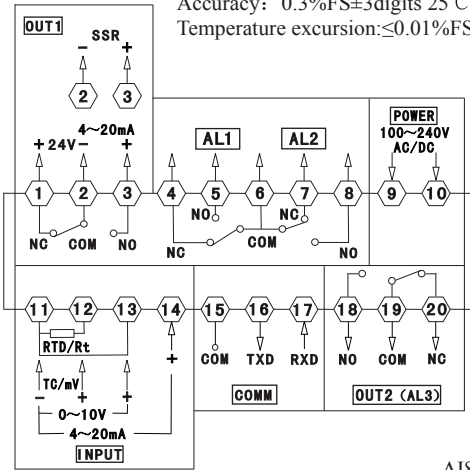

AI808P Series Temperature Adjustor
 Model: AI808P-4
 Accuracy: 0.3%FS±3digits 25℃
 Temperature excursion:≤0.01%FS/℃

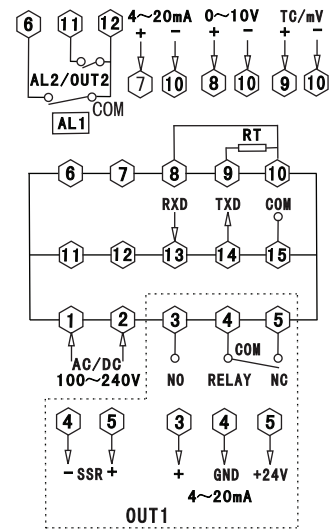

AI808P Series Temperature Adjustor
 Model: AI808P-7
 Accuracy: 0.3%FS±3digits 25℃
 Temperature excursion:≤0.01%FS/℃

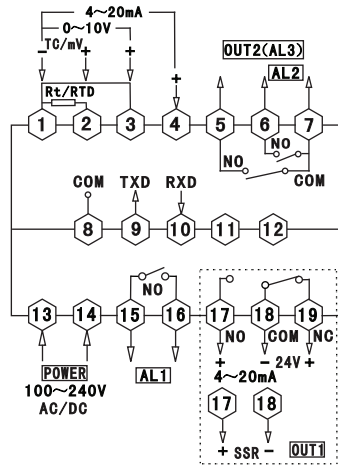

Note: If there is any change, please subject to the drawing on the meter!

11. Simple Problem Shooting

Display Message	Shooting Method
Display HHHH	Input disconnect or over upper limit, please check input signal, FH value and ambient working temperature.
Display LLLL	Input disconnect or under lower limit, please check input signal, FL value and ambient working temperature.

11.Communication

AI808P series adjustor follow Modbus RTU communication protocol, and it can run RS485 half-duplex communication. Read function code is 0x03, write function code is 0x10, 16-bit CRC checking is applied. The coulometer can not return error message.

Data Frame flag:

Start bit	Data bit	Stop bit	Check bit
1	8	2	None

1. Read Multiple Registers

For example: The host computer read the float number AL1 (The value of Alarm 1 is 15.4).The address code of AL1 is 0x0000, for AL1 is float number (4bits), it will occupy 2 data register. Reference IEEE-574 standard the hexadecimal 16 result of the decimal float number is 0x41766666.

Request from the host computer (Read Multiple Registers)							
1	2	3	4	5	6	7	8
Unit Address	Function code	Start Address Hi	Start Address Lo	Data length Hi	Data length Lo	CRC code Lo	CRC code Hi
0x01	0x03	0x00	0x02	0x00	0x04	0xE5	0xC9

Correct answer from slave unit (Read Multiple Registers)								
1	2	3	4	5	6	7	8	9
Address	Function code	Data byte No.	Data1 Hi byte	Data1 Lo byte	Data2 Hi byte	Data2 Lo byte	CRC Code Lo	CRC Code Hi
0x01	0x03	0x04	0x41	0x76	0x66	0x66	0xE2	0xF4

2. Write Multiple Registers

For example: The host computer write the float number (setting value 600) ,

The address code for SV is 0x0000, for SV is float number (4bits), it will occupy 2 data register. Reference IEEE-574 standard the hexadecimal 16 result of the decimal float number is 0x41766666.

Request from the host computer (Write Multiple Registers)												
1	2	3	4	5	6	7	8	9	10	11	12	13
Unit address	Function Code	Start address Hi	Start address Lo	Data Length Hi	Data Length Lo	Data Length	Data 1 Hi	Data 1 Lo	Data 2 Hi	Data 2 Lo	CRC Lo	CRC Hi
0x01	0x10	0x00	0x00	0x00	0x02	0x04	0x44	0x16	0x00	0x00	0xFD	0xFC

Correct answer from slave unit (Read Multiple Registers)							
1	2	3	4	5	6	7	8
Unit address	Function Code	Start address 8 Hi	Start address 8 Lo	Data Length Hi	Data Length Lo	CRC Lo	CRC Hi
0x01	0x10	0x00	0x00	0x00	0x02	0x41	0xC8

AI808P Series table reference address

Code	Reference address	Number of Variable	Data Length	Read & Write allow	Remark
0	0x0000	Setting Value SV	2	R/W	
2	0x0002	Alarm value AL1	2	R/W	
4	0x0004	Alarm value AL2	2	R/W	
6	0x0006	Alarm value AL3	2	R/W	
8	0x0008	Correct value PS	2	R/W	
10	0x000A	Proportion rate P	2	R/W	
12	0x000C	Integral time I	2	R/W	
14	0x000E	Differential ID	2	R/W	
16	0x0010	ON/OFF Control Hysteresis HY	2	R/W	
18	0x0012	Heating & cooling dead district DB	2	R/W	
20	0x0014	Alarm 1 Hysteresis HY1	2	R/W	
22	0x0016	Alarm 2 Hysteresis HY2	2	R/W	
24	0x0018	Alarm 2 Hysteresis HY3	2	R/W	
26	0x001A	Control output Lo OLL	2	R/W	
28	0x001C	Control output Hi OLH	2	R/W	
30	0x001E	Display Lo FL	2	R/W	
32	0x0020	Display Hi FH	2	R/W	
34	0x0022	Analog Lo Value	2	R/W	
36	0x0024	Analog Hi Value	2	R/W	
38	0x0026	Measuring Value	2	R	

Code	Reference address	Number of Variable	Data Length	Read & Write allow	Remark
40	0x0028	Auto/Manual free change	1	R	
42	0x002A	Lock LCK	1	R	
44	0x002C	Control output OT	1	R	
46	0x002E	Heating control Turn CT	1	R	
48	0x0030	Cooling proportion C_P	1	R	
50	0x0032	Cooling control Turn C_CT	1	R	
52	0x0034	Alarm 1 mode AD1	1	R	Note1
54	0x0036	Alarm 2 mode AD2	1	R	Note1
56	0x0038	Alarm 2 mode AD2	1	R	Note1
58	0x003A	Input signal select INP	1	R	Note2
60	0x003C	Decimal DP	1	R	
62	0x003E	Filter FT	1	R	
64	0x0040	Baud rate BAD	1	R	Note3
66	0x0042	Address ADD	1	R	
68	0x0044	Programmable Value STEP	1	R	
70	0x0046	The 1 section setting value SV1	2	R/W	
72	0x0048	The 1 section status setting value ST1	2	R/W	
74	0x004A	The 2 section setting value SV2	2	R/W	
76	0x004C	The 2 section status setting value ST2	2	R/W	
78	0x004E	The 3 section setting value SV3	2	R/W	
80	0x0050	The 3 section status setting value ST3	2	R/W	
82	0x0052	The 4 section setting value SV4	2	R/W	
84	0x0054	The 4 section status setting value ST4	2	R/W	
86	0x0056	The 5 section setting value SV5	2	R/W	
88	0x0058	The 5 section status setting value ST5	2	R/W	
90	0x005A	The 6 section setting value SV6	2	R/W	
92	0x005C	The 6 section status setting value ST6	2	R/W	
94	0x005E	The 7 section setting value SV7	2	R/W	
96	0x0060	The 7 section status setting value ST7	2	R/W	
98	0x0062	The 8 section setting value SV8	2	R/W	
100	0x0064	The 8 section status setting value ST8	2	R/W	
102	0x0066	The 9 section setting value SV9	2	R/W	
104	0x0068	The 9 section status setting value ST9	2	R/W	
106	0x006A	The 10 section setting value SV10	2	R/W	
108	0x006C	The 10 section status setting value ST10	2	R/W	
110	0x006E	The 11 section setting value SV11	2	R/W	
112	0x0070	The 11 section status setting value ST11	2	R/W	
114	0x0072	The 12 section setting value SV12	2	R/W	
116	0x0074	The 12 section status setting value ST12	2	R/W	
118	0x0076	The 13 section setting value SV13	2	R/W	

Code	Reference address	Variable Name	Data Length	Read & Write allow	Remark
120	0x0078	The 13 section status setting value ST13	2	R/W	
122	0x007A	The 14 section setting value SV14	2	R/W	
124	0x007C	The 14 section status setting value ST14	2	R/W	
126	0x007E	The 15 section setting value SV15	2	R/W	
128	0x0080	The 15 section status setting value ST15	2	R/W	
130	0x0082	The 16 section setting value SV16	2	R/W	
132	0x0084	The 16 section status setting value ST16	2	R/W	
134	0x0086	The 17 section setting value SV17	2	R/W	
136	0x0088	The 17 section status setting value ST17	2	R/W	
138	0x008A	The 18 section setting value SV18	2	R/W	
140	0x008C	The 18 section status setting value ST18	2	R/W	
142	0x008E	The 19 section setting value SV19	2	R/W	
144	0x0090	The 19 section status setting value ST19	2	R/W	
146	0x0092	The 20 section setting value SV20	2	R/W	
148	0x0094	The 20 section status setting value ST20	2	R/W	
150	0x0096	The 21 section setting value SV21	2	R/W	
152	0x0098	The 21 section status setting value ST21	2	R/W	
154	0x009A	The 22 section setting value SV22	2	R/W	
156	0x009C	The 22 section status setting value ST22	2	R/W	
158	0x009E	The 23 section setting value SV23	2	R/W	
160	0x00A0	The 23 section status setting value ST23	2	R/W	
162	0x00A2	The 24 section setting value SV24	2	R/W	
164	0x00A4	The 24 section status setting value ST24	2	R/W	
166	0x00A6	The 25 section setting value SV25	2	R/W	
168	0x00A8	The 25 section status setting value ST25	2	R/W	
170	0x00AA	The 26 section setting value SV26	2	R/W	
172	0x00AC	The 26 section status setting value ST26	2	R/W	
174	0x00AE	The 27 section setting value SV27	2	R/W	
176	0x00B0	The 27 section status setting value ST27	2	R/W	
178	0x00B2	The 28 section setting value SV28	2	R/W	
180	0x00B4	The 28 section status setting value ST28	2	R/W	
182	0x00B6	The 29 section setting value SV29	2	R/W	
184	0x00B8	The 29 section status setting value ST29	2	R/W	
186	0x00BA	The 30 section setting value SV30	2	R/W	
188	0x00BC	The 30 section status setting value ST30	2	R/W	
190	0x00BE	The 31 section setting value SV31	2	R/W	
192	0x00C0	The 31 section status setting value ST31	2	R/W	
194	0x00C2	The 32 section setting value SV32	2	R/W	
196	0x00C4	The 32 section status setting value ST32	2	R/W	
198	0x00C6	The33 section setting value SV33	2	R/W	
200	0x00C8	The 33 section status setting value ST33	2	R/W	
202	0x00CA	The 34 section setting value SV34	2	R/W	
204	0x00CC	The 34 section status setting value ST34	2	R/W	
206	0x00CE	The 35 section setting value SV35	2	R/W	
208	0x00D0	The 35 section status setting value ST35	2	R/W	
210	0x00D2	The 36 section setting value SV36	2	R/W	
212	0x00D4	The 36 section status setting value ST36	2	R/W	
214	0x00D6	The 37 section setting value SV37	2	R/W	

Code	Reference address	Variable Name	Data Length	Read & Write allow	Remark
216	0x00D8	The 37 section status setting value ST37	2	R/W	
218	0x00DA	The 38 section setting value SV38	2	R/W	
220	0x00DC	The 38 section status setting value ST38	2	R/W	
222	0x00DE	The 39 section setting value SV39	2	R/W	
224	0x00E0	The 39 section status setting value ST39	2	R/W	
226	0x00E2	The 40 section setting value SV40	2	R/W	
228	0x00E4	The 40 section status setting value ST40	2	R/W	
230	0x00E6	The 41 section setting value SV41	2	R/W	
232	0x00E8	The 41 section status setting value ST41	2	R/W	
234	0x00EA	The 42 section setting value SV42	2	R/W	
236	0x00EC	The 42 section status setting value ST42	2	R/W	
238	0x00EE	The 43 section setting value SV43	2	R/W	
240	0x00F0	The 43 section status setting value ST43	2	R/W	
242	0x00F2	The 44 section setting value SV44	2	R/W	
244	0x00F4	The 44 section status setting value ST44	2	R/W	
246	0x00F6	The 45 section setting value SV45	2	R/W	
248	0x00F8	The 45 section status setting value ST45	2	R/W	
250	0x00FA	The 46 section setting value SV46	2	R/W	
252	0x00FC	The 46 section status setting value ST46	2	R/W	
254	0x00FE	The 47section setting value SV47	2	R/W	
256	0x0100	The 47 section status setting value ST47	2	R/W	
258	0x0102	The 48 section setting value SV48	2	R/W	
260	0x0104	The 48 section status setting value ST48	2	R/W	
262	0x0106	The 49 section setting value SV49	2	R/W	
264	0x0108	The 49 section status setting value ST49	2	R/W	
266	0x010A	The 50 section setting value SV50	2	R/W	
268	0x010C	The 50 section status setting value ST50	2	R/W	
270	0x010E	program Section Operating Status	1	R	Note 4
272	0x0110	Output Alarm Status	1	R	Note 5

R: Read only; R/W: Read/Write

Parameter setting range , please referring to products user's manual

Note 1: Alarm Mode

Alarm Mode	Upper Alarm	Lower Alarm	Upper deviation alarm	Lower deviation alarm
Corresponding values	0	1	2	3

Note 2: Input Signal (please refer to input parameter table)

Note 3:

Baud rate BAD	4.8K	9.6K
Data value	0	1

Note 4: Operating Status

Operating Status	STOP	RUN	HOLD
Corresponding values	0	1	2

Note 5: Output Alarm Status (1 means ON, 0 means OFF)

Parameter bits	7	6	5	4	3	2	1	0
Control Status			AT	AL3	AL2	AL1	OUT2	OUT1

16 digit CRC verify program

```
unsigned int Get_CRC(uchar *pBuf, uchar num)
{
    unsigned i,j;
    unsigned int wCrc = 0xFFFF;
    for(i=0; i<num; i++)
    {
        wCrc ^= (unsigned int)(pBuf[i]);
        for(j=0; j<8; j++)
        {
            if(wCrc & 1){wCrc >>= 1; wCrc ^= 0xA001; }
            else
                wCrc >>= 1;
        }
    }
    return wCrc;
}
```